

REISHAUER

Gear Grinding Technology

Reishauer RCL x60



MACHINE

AUTOMATION

TOOLING

TECHNOLOGY

DIGITAL

SERVICE

Compact loader system up to \varnothing 260 mm



Swiss Precision. Made by Reishauer.



Compact, user-friendly loader system

With the loader system formerly marketed under the name CompactLoader, Reishauer has expanded its existing automation portfolio in line with the Circle of Competence: As an ideal addition, the Reishauer RCL line rounds off the product range with a basic version for all Reishauer RZ x60 4.0 generating grinding machines. Furthermore, this loader line offers a variant for the Reishauer universal grinding machines of type RZ 410. In principle, the loader is also suitable for the larger RZ 550 and RZ 1000 machines. Nevertheless, it remains limited in terms of workpiece diameter and weight.

Loader systems offer the customer functions that supplement the production process before and after the grinding operation. Integrated monitoring and ejection functions ensure a consistently high quality of output. These features help our customers to organize production efficiently and cost-effectively. The Reishauer RCL line was developed to meet demanding production requirements. It is valued worldwide for its reliability in multi-shift operations.

For optimum utilization of your production capacity

The Reishauer RCL line is a highly efficient automation system for loading disk- and shaft-type gears, widely used in the gear industry. It reduces unproductive downtime and can be finely tuned to your needs through numerous configuration options.

A loader system with short changeover times

Our customers place high demands on automation technology – focusing on speed, efficiency, and compactness. For this reason, our RCL line features fast loading and short changeover times. Several hundred storable workpiece programs enable a changeover process in less than ten minutes without requiring tools. Teaching new, non-stored workpieces takes about 20 minutes. This simple and time-saving operation is also appreciated by the personnel, who are trained in all the important functions of the loader in less than two hours.

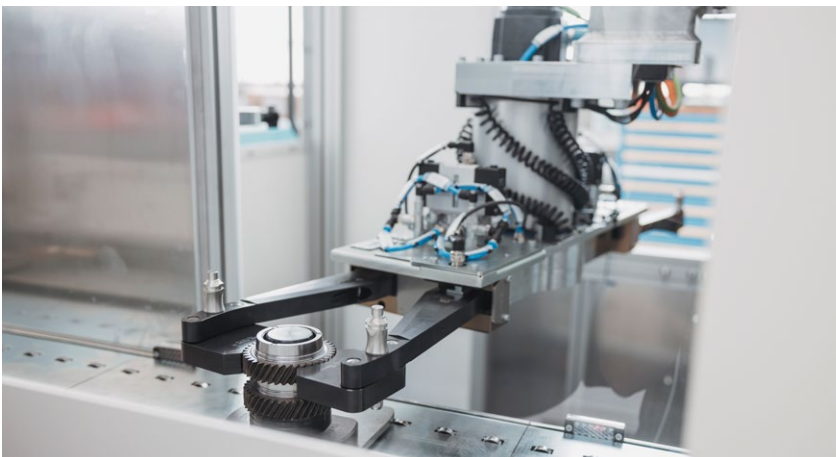

With an extremely compact footprint of just 6m² in its minimal configuration, the RCL x60 helps you to reduce space requirements. However, if a high conveyor belt autonomy is required, various extensions are available for additional conveyor belt storage.

The design focuses on long maintenance intervals and low maintenance effort. A minimum of necessary maintenance interventions ensures maximum Overall Equipment Effectiveness, allowing your production capacity to be optimally utilized.

The Reishauer RCL x60 offers:

- Connectivity to the Reishauer RZ x60 4.0 gear grinding machines
- Single and double gripper options available
- User-friendly due to semi-automatic, intuitive workpiece teaching
- Short set-up times thanks to storable workpiece programs
- Completely tool-free changeover
- Minimal footprint of approx. 6m² with standard belt storage
- Optimally integrated belt storage, extensions available
- Low maintenance requirements
- Swiss Made

Modular design in line with your requirements

Our standard design is highly versatile and can meet many of your requirements. We have simplified automated loading to ensure you benefit from the reliability and affordability of a proven product. The Reishauer RCL line is designed as a modular loader system, providing an excellent compromise for most required applications. It is engineered to be an easy-to-use, robust, and reliable loader, fulfilling this role worldwide for many years.



Automating existing gear grinding machines

The automation in the RCL line has its own control systems. It communicates with the grinding machine via a neutral interface. In many cases, Reishauer generating grinding machines of the previous generation can also be retrofitted with this loader system.

Future-proof investment

Technology and requirements are continually evolving. The modularity of the Reishauer RCL line allows upgrading existing systems to adapt to changing demands. Adding functions from the options package can be achieved with reasonable effort, making the system future-proof.

Alternative Reishauer solution for extended functionality requirements

The Reishauer RCL line is a highly efficient and low-maintenance system that reliably performs its task with minimal setup effort. However, suppose there are requirements such as loading stack cells, integrating workpiece measurement systems, or other features. In that case, the Reishauer portfolio offers the following solution: The Reishauer RL x60. This loader is specially designed for such requirements. It can cover an almost complete range of functionalities with its even more extensive option package.

For more information, please contact your Reishauer representative.

Technical Data and Options

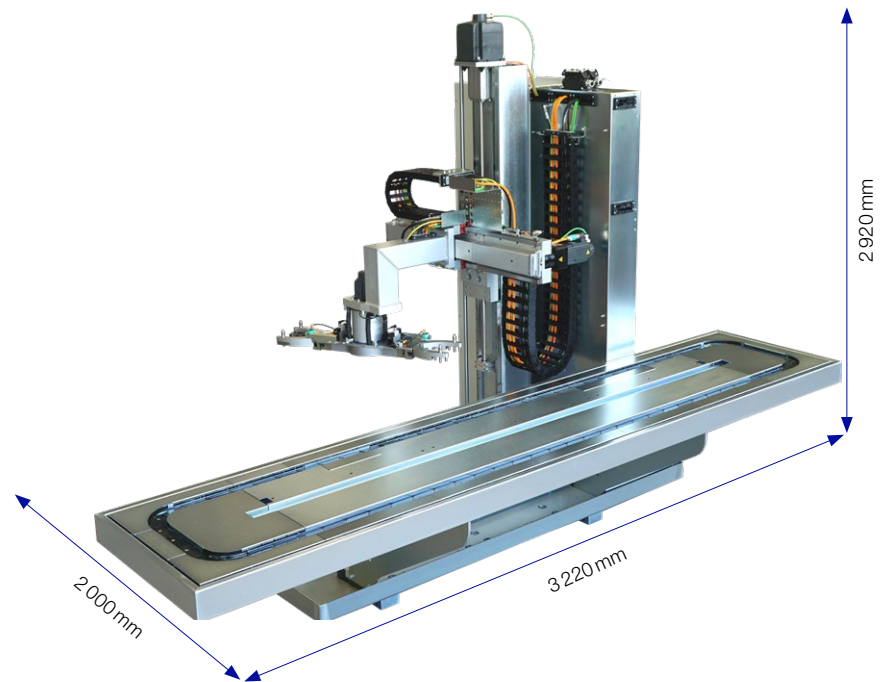
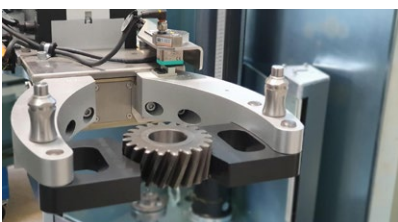
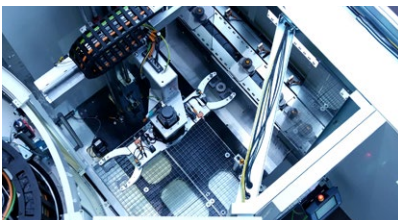

	RCL x60	RL x60
Workpiece diameter max.	260 mm	260 mm
Shaft length max.	400 mm ¹⁾	490 mm
Gripper	single / double	single / double
Workpiece weight max.	1 x 20 kg / 2 x 20 kg	1 x 25 kg / 2 x 13 kg
Total load belt storage max.	380 kg	500 kg
Stacking available	yes	yes
Further workpiece storages available	no	stacking cell, drawer storage unit and more
NOK / SPC-station	2 – 6 slots	2 – 9 slots
Oil centrifuge available	yes	yes
Deburring available	no	yes
Horizontal workpiece position available	no	yes
Upgradable from machine number ²⁾	78 202	78 202
Weight	2 500 kg	4 000 kg

1) Up to 490mm possible. Not compatible with NOK/SPC station. 2) Technical assessment required. Former machine generations available upon request. Subject to technical changes.

Equipment

Standard Equipment

C-axis: planetary gear, synchronous motor, swivel arm with gripper

Y-axis: linear guideway, timing belt, planetary gear, synchronous motor

Z-axis: linear guideway, ball screw spindle, synchronous motor

Central lubrication with oil tank

Integrated belt storage

Peripheral system: electrical cabinet, housing, oil pan, leveling elements

Interfaces: ProfiNet and Multipol communication

Remote maintenance

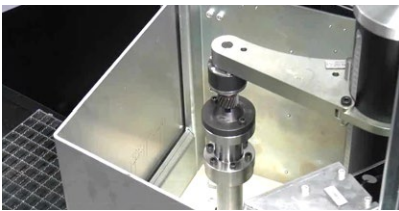

Options

Oil centrifuge

NOK/SPC station, configurable with up to six positions

Workpiece detection using contour masks

Workpiece stacking

Integration of external belt storage

Integration of third-party systems (robotic)

Camera system

Control

PLC: Siemens S7-1500

HMI: Siemens SIMATIC KTP 700 F

Reishauer Circle of Competence

The Reishauer Circle of Competence encompasses our complete range of products and services. By offering everything related to the grinding process from a single source, Reishauer ensures a long service life of the machine system at low life cycle costs.

Machine

A broad portfolio, future-oriented controls, and interface concepts, and state-of-the-art grinding technologies – for decades, our machines have guaranteed the highest possible output with maximum precision, consistent quality, and unmatched machine availability.

Automation

Automation "Made by Reishauer". Our automation solutions are perfectly matched to our machines and keep pace with their high output. Modular in design, they can be flexibly tailored to your production needs.

Tooling

Perfectly matched, consistent in quality, and with guaranteed availability: Together with the machine, Reishauer tooling forms the backbone of successful grinding processes.

Technology

Modern e-drives demand higher overall gear quality, clearly defined surface finishes, and highly accurate gear geometries. Reishauer grinding technologies enable you to meet your and your customer's most demanding requirements and help you remain competitive. Our technology experts are at your disposal to advise you and provide support.

Digital

System integration, in-depth process analyses, and predictive maintenance – the requirements for Industry 4.0 solutions are extremely complex and diverse. Reishauer offers a constantly growing portfolio of digital services to maximize the potential of your machines.

Services

The reliability of our machines, and thus machine availability, is of central importance for your competitiveness. Shortest reaction time, a worldwide extended network of service engineers, and decentralized spare parts stores guarantee maximum availability.



Reishauer worldwide

SWITZERLAND

Reishauer AG
Industriestrasse 36
8304 Wallisellen
Switzerland
☎ +41 44 832 22 11
info@reishauer.com

GERMANY

Reishauer GmbH
Humboldtstrasse 32
70771 Leinfelden-Echterdingen
Germany
☎ +49 711 947 56 0
germany@reishauer.com

CHINA

Reishauer AG
Beijing Representative Office
Room 1708, SCITECH TOWER
No. 22 Jian Guo Men Wai Da Jie
Beijing 100004
China
☎ +86 10 651 571 75
china@reishauer.com

USA

Reishauer Corp.
1525 Holmes Road
Elgin, IL 60123
USA
☎ +1 847 888 38 28
usa@reishauer.com

FRANCE

Reishauer AG
21 Rue de la Croix Blanche
33000 Bordeaux
France
☎ +33 6 0830 64 20
france@reishauer.com

JAPAN

Reishauer K.K.
2-14-30 Shinyokohama
Kohoku-ku, Yokohama-shi
222-0033 Kanagawa
Japan
☎ +81 45 476 58 33
japan@reishauer.com

Find additional representatives at www.reishauer.com

Head Office:

Reishauer AG

Industriestrasse 36
8304 Wallisellen
Switzerland
☎ +41 44 832 22 11
reishauer.com

REISHAUER

Gear Grinding Technology